



## A COMPACT SOLUTION THAT'S PLEASING TO THE PALLET

**QComp's Innovative COMPACT LEAN PALLETIZER** allows you to palletize at your point of production, eliminating long and costly conveyor runs to centralized palletizing areas. The Compact Lean Palletizer features the reliable ABB IRB 260 robot, a durable robust machine that boasts a packing rate of up to 15 cases per minute. What makes this low cost pre-engineered palletizer especially attractive is its compact modular design that frees up valuable floor space. And its fast project ROI make this investment even more palletable!

### The QComp Advantages & Benefits:

- Palletize at point of production
- Fast project Return on Investment
- Uses manual forklifts or AGV's
- Pre-assembled for quick startup
- Integrates with AGV for transport of full pallets to stretch wrapper
- Multiple pallet patterns available
- Eliminates long conveyor runs
- Utilizes ABB Pickmaster 5 software
- Instantaneous tool changing

**Call for more information or to schedule a free demonstration.**

W6564 Quality Drive  
Greenville, WI 54943

ph: 920.757.0775  
fx: 920.757.9961

www.qcomptech.com  
info@qcomptech.com

### SPECIFICATIONS

- Case weights up to 45 lbs
- 36" scissors lift for max height
- 86" pallet height
- Up to 15 cases per minute
- ABB IRB 260 robot
- Rockwell MicroLogix 1500 PLC

### OPTIONS

- Integrated AGV for empty and full pallet handling
- Pallet dispenser
- Slip sheet
- Straight thru or over/under layout

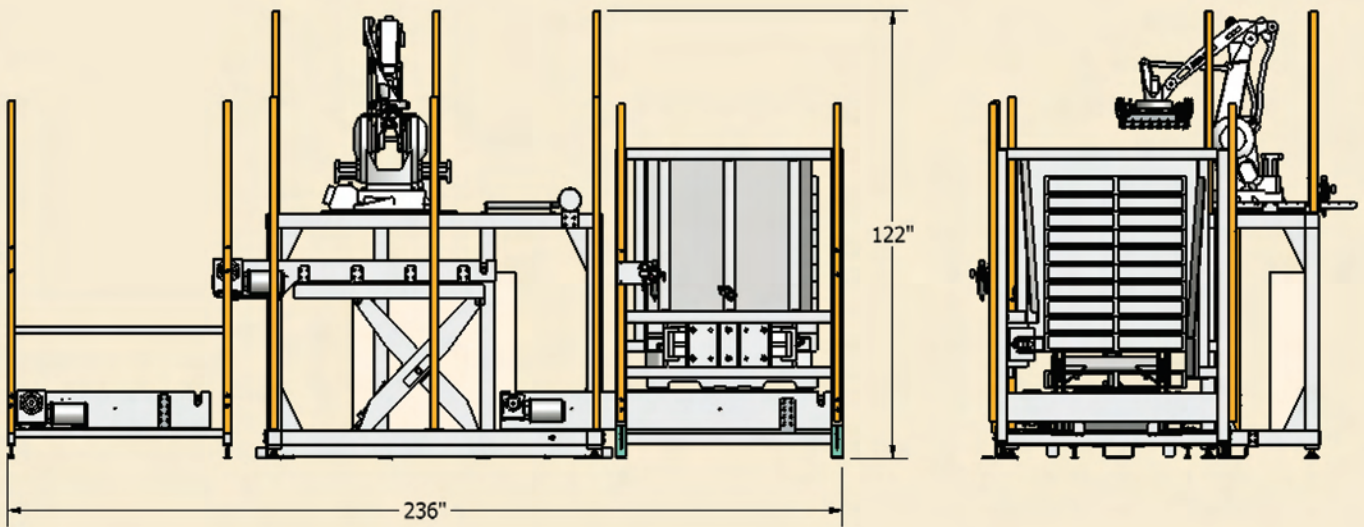
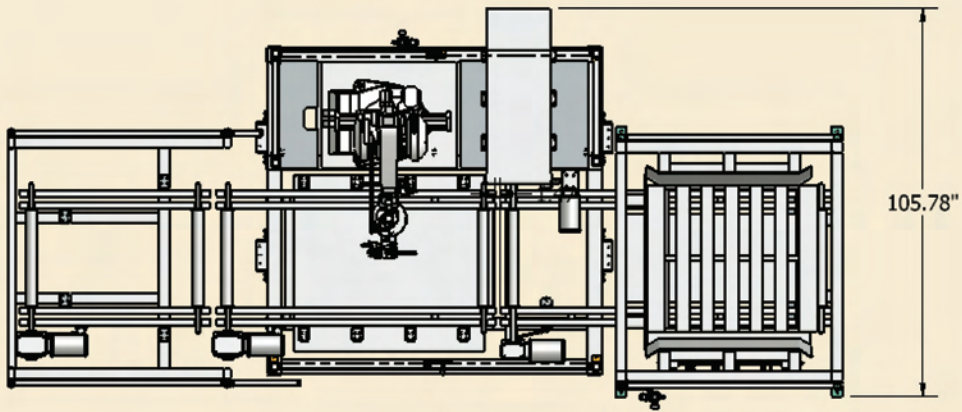

## QCOMP COMPACT LEAN PALLETIZER

